

# LOW COST ORGANIC RANKINE CYCLES FOR GRID CONNECTED POWER GENERATION

Thomas. C. B. Smith

Hopkinson Laboratory, University dept. of Engineering, Trumpington Street, Cambridge, CB2 1PZ, England  
Tel:+44 1223 332 681, Fax:+44 1223 765 311, e-mail: tcbs2@cam.ac.uk

**Abstract** – The commercial feasibility of small scale solar ORC for distributed generation and CHP is demonstrated. This has been achieved with an exergy analysis of over 150 commercially available solar hot water collectors, a survey of candidate working fluids and by adapting rotary refrigeration compressors to run in reverse direction as expanders/asynchronous generators. A computer code combining the results of these sub-studies has demonstrated that self-stabilisation close to optimum conditions for given irradiance may be possible without electronic feedback control.

The principle obstacles encountered included oil migration, face and tip sealing problems and low expansion ratios.

Electrical Capacity Costs of €3.7 to €3.4/We (1KWe capacity) and €3.3 to €3.8/We (2KWe capacity) at  $G=1000\text{W/m}^2$  were estimated. A significant improvement on these figures is possible if a large cooling reservoir is available.

Construction of a field prototype will involve developing a high volumetric ratio, purpose built expander in collaboration with a compressor manufacturer and optimising a liquid piston pump which is being developed specifically for ORC feed-pumping.

## 1. INTRODUCTION

The attractions of using heat engines for distributed solar rooftop generation and stand alone applications are many fold.

Apart from implying lower system costs and higher materials savings, rooftop heat engines offer domestic scale CHP and cooling capability through hybridisation with absorption cycles (Tamm and Goswami, 2003). Significant opportunity for component ‘cost sharing’ increases market feasibility by an encouraging extent.

In recent years, a number of studies of Organic Rankine Cycles (ORC) for small scale applications have been conducted, eg: (Martin et. al., 2002), (Gnutek and Bryszewska-Mazurek, 2001) which focus mainly on stand alone applications.

This study is concentrated specifically on estimating a minimum achievable Capacity Cost ( $C_T$ , per peak Watt) and integrated Life Cycle Cost ( $C_L$ , per KWh) of a grid connected solar ORC plant, in order to determine the level of commercial feasibility on market entry production levels. It is assumed that condenser heat may be removed by process loads or pre-existing capacity for waste heat removal. Land use and installation costs have been neglected. The figures determined do not account for cost sharing of additional components or energy savings through effective hybridisation with external systems.

The collectors included in the study are constrained to non-tracking, non-concentrating or low concentration solar thermal collectors. The SPF database was used to obtain a number of collector parameters and a retail price index.

The study is comprised of experimental and modelling elements to determine the feasibility of a number of cost saving innovations in the system design.

Cost minimisation has proceeded via a 3 part approach:

- Use of pre-developed components with existing production lines wherever possible.
- Elimination of additional heat exchangers and efficiency improving mechanisms which cannot be justified with a significant  $C_T$  or  $C_L$  margin.
- Alleviation of the need for electronic feedback control through prioritisation of auto-stability and effective dynamic response.

The  $C_T$  of the entire ORC system is the sum of the costs of the individual components divided by the system output.

$$C_T = \frac{\sum_i c_i}{G \prod_j \eta_j} \quad \text{Eq. (1)}$$

where  $c_i$  are the costs and  $\eta_j$  are the efficiencies of the components in energetic series and  $G$  is the net solar irradiance.

To a reasonable approximation, this may be reduced to

$$C_T = \frac{c_{coll} + c_{con} + c_{exp} + c_{gen}}{G \eta_{coll} \eta_{th} \eta_{exp} \eta_{gen}} \quad \text{Eq. (2)}$$

where the cost suffixes refer to collector, condenser, expander and generator (including signal processing) and the efficiency suffixes refer to the collector, thermodynamic cycle, expander and generator

respectively. It is assumed that as in a refrigeration cycle evaporator, vapour may be generated directly in the absorber and a separate boiler is not required.

The cost of each component depends on its individual efficiency. Although any functional relationships fitted to manufacturer's data are tenuous, broad trends may be observed. A plot of collector efficiencies at their optimal performance points, at which exergy collected is maximized for given irradiation reveals the extent to which this is the case:

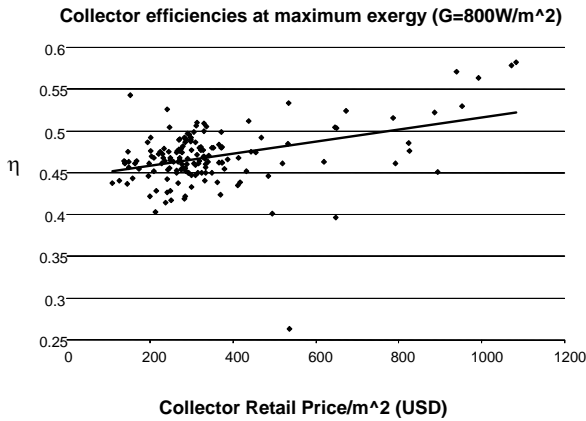

This enables a simple linear relation to be plotted between collector cost and efficiency:

$$c_{coll} \approx k_1 + k_2 \eta_{coll} \quad \text{Eq. (3)}$$

The cost of a given type of condensing heat exchanger can be considered to be linearly proportional to the condensing heat load at given inlet and exit conditions with a greater degree of accuracy than for the collectors.

Cost and performance data for a small number of commercially available heat exchanger designs were gathered in order to draw some broad conclusions. A counterflow brazed plate design was chosen. Retail prices for these models are quoted as a linear function of the number of plates. ie:

$$c_{con} = k_3 + k_N N \quad \text{Eq. (4)}$$

where N is the number of plates.

As the heat load at constant inlet and exit conditions is proportional to the number of plates;

$$c_{con} = k_3 + k_4 Q_{con} = k_3 + k_4 G \eta_{coll} (1 - \eta_{th}) \quad \text{Eq. (5)}$$

Therefore, equation (2) can be reduced to;

$$C_T = \frac{1}{\eta_{exp} \eta_{gen}} \underbrace{\left( \frac{k_1 + k_2 \eta_{coll} + k_3 + k_4 G \eta_{coll} (1 - \eta_{th})}{G \eta_{coll} \eta_{th}} \right)}_{\text{Term a}} + \frac{1}{G \eta_{coll} \eta_{th}} \underbrace{\left( \frac{c_{exp}(\eta_{exp}) + c_{gen}(\eta_{gen})}{\eta_{exp} \eta_{gen}} \right)}_{\text{Term b}} \quad \text{Eq. (6)}$$

The first bracketed term (a) in equation A1.6 is the *cost per Watt of isentropic power supplied to the expander* and is independent of the expander or generator parameters. Similarly, the second bracketed term (b), which is the *cost per Watt of electricity produced from available isentropic power*, is independent of the collector and heat exchanger parameters.

It is clear that the collector and condenser must be selected and optimized ensemble due to the strong functional dependence of condenser cost on collector efficiency and thermal efficiency.

Therefore the total collector plus condenser cost per *electrical* output (term 1) may be optimized entirely independently of the total expander plus generator cost per electrical output (term 2). Furthermore, if low cost positive displacement machines, such as rotary refrigeration compressors may be used as expanders *without* a measurable compromise in the polytropic expansion efficiency, the first of these two terms may be assumed considerably greater than the second above certain capacities. The validity of this assumption was later confirmed.

A quantitative approach such as this to *expander* and *generator* selection is not prudent, as only a small sample of expanders may be considered and many factors other than cost and efficiency must be accounted for during their selection.

In order to proceed further with collector and condenser selection to optimize term (a) in equation A1.6, a functional connection between  $\eta_{coll}$  and  $\eta_{th}$  must be determined.

## 2. PARAMETRIC OPTIMISATION

### 2.1 Collector selection

Empirically measured steady state efficiencies of over 150 collectors are given by the SPF catalogue in terms of their quadratic coefficients  $c_0$ ,  $c_1$  and  $c_2$ , according to:

$$\eta_{coll}(T) = c_0 - c_1 GX - c_2 GX^2 \quad \text{Eq. (7)}$$

where  $X = \frac{T - T_a}{G}$ , T is the mean fluid temperature and  $T_a$  is the temperature of the ambient surroundings.

The *thermodynamic* efficiency,  $\eta_{th}$  varies greatly from one working fluid to another. As it is a highly idealised quantity it is typically quite high at around 80% of the Carnot efficiency, ie:

$$\eta_{th} \approx 0.8 \left( 1 - \frac{T_c}{T} \right) \quad \text{Eq. (8)}$$

where  $T_c$  is the condensing temperature. In order to relate  $\eta_{th}$  to  $\eta_{coll}$ ,  $T_c$  must be re-expressed in terms of  $T_a$  and inevitably also depends on the capacity and effectiveness of the condenser.

If the heat load transmitted by the condenser for given coolant mass flow,  $Q_{con}$  is given approximately by:

$$Q_{con} \approx \frac{(T_c - T_a)N}{k_5} \quad \text{Eq. (9)}$$

where  $N$  is the number of condenser plates and  $k_5$  is determined from manufacturer's data, then combining equation (9) with equation (5):

$$T_c = T_a + \frac{0.2G\eta_{coll}k_5(T_a + 4T)}{NT - 0.8Gk_5\eta_{coll}} \quad \text{Eq. (10)}$$

Substituting equation (10) into equation (8), and then the resulting equation together with equation (7) into term (a) of equation (6) yields an expression for the *cost per Watt of isentropic power supplied to the expander* in terms of the collector and condenser parameters and the number of plates. This is minimized numerically with respect to the number of plates to obtain a figure which enables a collector-condenser combination to be selected.

The resulting distribution of capacity costs of the collectors including implied condensing costs is presented below.

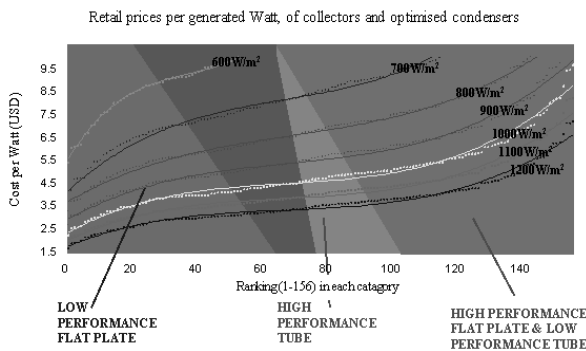

## 2.2 Selection of candidate working fluids

After conducting the collector and condenser survey and exergy analysis, a broad range of collecting and condensing temperatures is available and enables working fluids to be considered in greater detail.

As there is a thermodynamic advantage in raising boiler pressure rather than adding superheat, and high effectiveness can be achieved at much lower cost when a phase change is involved, the study focused on fluids well suited to expansion from near saturated conditions. These may be subdivided into non-retrograde and retrograde fluids.

Retrogrades offer the possible advantage of remaining in the superheated region throughout the expansion and are particularly well suited to turbo-expansion, where blade erosion is a significant issue. However, using a retrograde fluid implies an exhaust temperature above condensing point so that either a recuperator must be employed or some efficiency loss must be accepted.

Another disadvantage of using a retrograde fluid is that a relatively high ratio of preheat to vapourisation heat must be added. Although this is well suited to collecting heat from a cooling fluid flow, such as a waste heat flue, it is not ideal for a solar-only heat source, as the exergetic efficiency of most collectors drops off sharply at collecting temperatures below optimum.

The figures below illustrate a possible cycle under two sets of operating conditions using typical non-retrograde and retrograde working fluids respectively. The solid cycle denotes operation under high irradiance and the dashed cycle under low irradiance.

T-S diagrams of possible ORCs under different conditions using retrograde and non-retrograde working fluids.

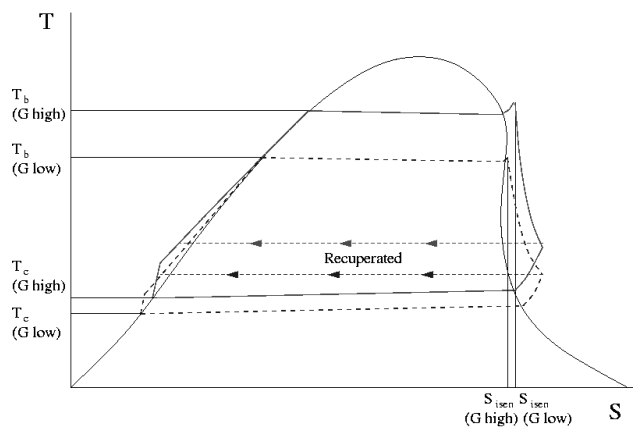
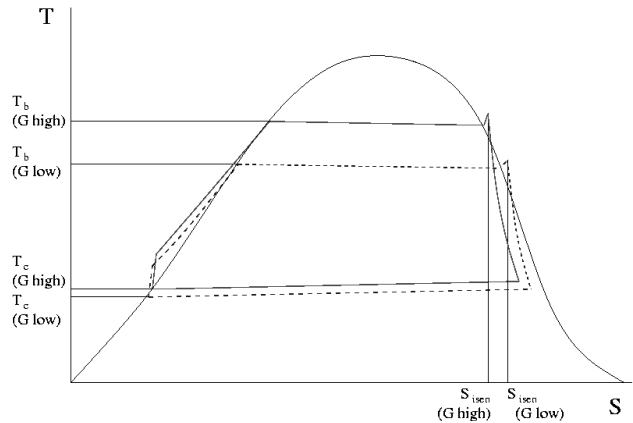

The high specific work output and lower specific losses associated with operating at high mean pressures must be traded off against increased material costs, safety issues and volumetric ratio requirements.

Using a commercial solar hot water collector usually limits safe operation to within 10 to 15 bars. In addition, efficient collection under variable irradiances requires a large degree of variability in the boiling temperature without significantly affecting condensing temperature or pressure ratio. This implies condensing at low pressures to maintain low absolute pressure dependence on temperature. Consequently, boiling pressures cannot be excessive or pressure ratios become very large.

At this point, some of the many advantages that positive displacement machines possess over turbines for this type of application become clear. Much higher pressure ratios are possible without multiple expansion stages and low, synchronous shaft speeds are feasible. In addition, positive displacement machines and particularly some rotary machines such as scrolls are very tolerant of wetness and slugging, which can even aid sealing and lubrication under certain conditions. Some scroll compressors are designed to allow liquid refrigerant to be injected into the scroll set during compression in order to cool the compression process and increase efficiency and net pressure ratio.

Taking these points into account, a spreadsheet containing thermodynamic properties of approximately 150 working fluid candidates was compiled. Tabulated empirical data were only found to be available in a small number of cases, eg: (Perry and Green, 1997). Liquid phase heat capacities of over 2000 Organic and Inorganic pure substances were found in (Zábranský et al.,1996) and used to calculate liquid phase specific enthalpies and entropies using the regressional fit;

$$\frac{c_p}{R} = A_1 \ln(1 - T_r) + \frac{A_2}{1 - T_r} + \sum_0^m A_{j+3} T_r \quad \text{Eq. (11)}$$

where  $A_i$  are quasi polynomial coefficients, valid within a stated temperature range up to the 6<sup>th</sup> order,  $T_r$  is the reduced temperature and  $R$  is the universal gas constant.

Simultaneously, enthalpies of vapourisation of 600 pure fluids were obtained (Majer and Svoboda ,1985) and entered using the suggested fit:

$$\Delta h_{fg} = A(1 - T_r)^\beta e^{-\alpha T_r} \quad \text{Eq. (12)}$$

Three figures of merit were thus determined for each working fluid included in the study:

1. Dryness fraction > 85%. at  $T=300\text{K}$ ,  $S=S_{\text{sat}}(400\text{K})$
2. High ratio of  $h_{fg}(400\text{K}) : h_f(400\text{K}) - h_f(300\text{K})$ .
3.  $v_g(300\text{K}, S_{\text{sat}}(400\text{K})) : v_g(400\text{K}, S_{\text{sat}}(400\text{K})) < 10:1$ .

The first and third of these criteria are a consequence of the mechanical limitations of the expander. Although

rotary positive displacement machines are more tolerant of droplet formation than turbines, a danger of slug formation and hydrodynamic lock does exist and exhaust dryness fractions should be maintained as high as possible. In addition, condensing flow cannot be considered to be in thermodynamic equilibrium. Consequently, expansion irreversibility generally increases as dryness decreases.

The second criterion was established purely on a thermodynamic basis in order to obtain the maximum ratio of isothermal to non-isothermal enthalpy increase. Equivalently, in order to maximise the exergy collected, the integrated temperature difference between the collector and working fluid is minimized throughout the preheating and boiling processes.

A shortlist of candidate pure working fluid and working fluid mixtures was compiled in order to enable system stability and performance limits to be estimated.

### 2.3 Retrofitting HVAC compressors as expanders

Rotary refrigeration compressors include rolling piston, screw, vane and scroll type designs amongst others. Rolling piston and Screw type machines are more commonly used in high capacity applications.

Compressors designed for refrigeration applications have higher compression ratios than air conditioning compressors and so in general are better suited to ORC.

Automotive air conditioning compressors are however of interest for laboratory tests as they are small and the drive shaft protrudes from the crank case via a dynamic seal. This permits shaft torque and speed measurements to be made with relative ease.

Measurements were made on automotive vane and scroll air conditioning compressors and a scroll type refrigeration compressor using compressed air.

Retrofitted terrestrial refrigeration scroll compressor after capping and flanging.

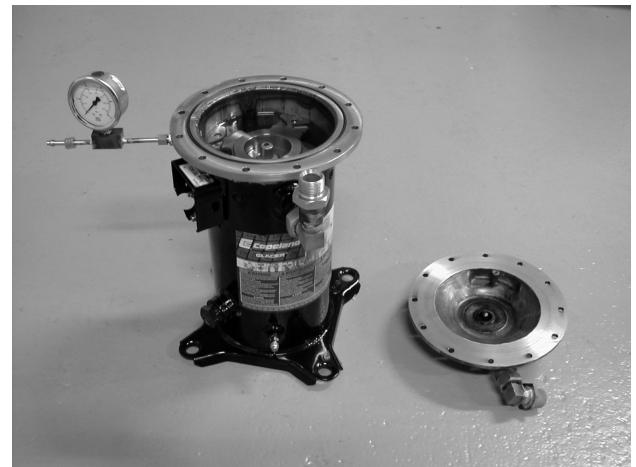

Preparation of the compressors for expanding an air flow involved the removal of check valves, changing of

the oil type and in the case of the terrestrial machine, extensive modification of the discharge port seals.

The automotive machines were loaded with a commutated DC motor with variable field current.

The terrestrial scroll is a fully hermetic design with an induction drive motor included. Rather than providing an external load, it was decided to characterise the drive motor and use it as an asynchronous brake.

Perhaps the most significant obstacle encountered in operating scroll machines as expanders is the control of oil migration. In automotive machines, the scroll set is bathed in lubricant so that some lubricant is carried to the scrolls with the intake vapour stream. In the terrestrial machine, oil is brought up to the underside of the orbiting scroll through the drive shaft and a small proportion is carried into the scroll set on the intake flow.

As the compressor sump is at low pressure and in the case of the expander, the intake is at high pressure, oil cannot be provided to the intake stream without first pumping it up to boiler pressure. This requires the provision of an oil pump. If the oil pump is to be driven by the main shaft, a significant, costly retrofit is implied.

A number of alternative options are feasible eg: (Kane et al., 2001), although each has associated drawbacks:

1. An impingent oil separator in the exhaust stream feeding separated lubricant back into the exhaust port.
2. Slightly over-expanding the flow so that some oil may be sucked into the exhaust port as in the compressor.<sup>1</sup>
3. Drilling a small hole in the static scroll, allowing oil to reach the condenser and feedpump and separating it off in the liquid phase before the boiling process commences. Then allowing the separated oil to be injected into the scroll set through a capillary.
4. Using elastomer end seals or one of a number of low friction coatings to replace oil entirely.

Each of these possibilities has a number of foreseeable advantages and drawbacks:

1. The first option requires no substantial adaptation of the compressor, but lubricant return maybe difficult to affect against a fast flowing exhaust stream, or may be intermittent and insufficient. In addition, impingent oil separators cause a significant pressure drop and imply an associated parasitic loss.
2. Whilst the second is the simplest option, insufficient suction would result in insufficient lubricant uptake and surplus suction would cause an unacceptable decrease in the efficiency of the expansion process.
3. This option is reasonably elegant, since some terrestrial scroll compressors (including the one acquired for the project) are fitted with a spur for liquid refrigerant injection in order to isothermally

---

<sup>1</sup> The expander exhaust port and compressor suction port are one in the same thing.

the compression process and increase the compression ratio.

4. The elastomer option may negate the sealing problem entirely, however, dynamic seals typically have a shorter lifetime than most other components in the compressor. Although they offer acceptable lubricity, unless the flow is sufficiently wet that the working fluid plays a role in sealing, blow by problems may still be an issue.

For the purposes of the project, option 4 was already applied to some extent in the automotive air conditioning compressor which is fitted with hardened gaskets and a dynamic Viton seal. Oil was not eliminated however.

In addition, an extra set of scrolls was acquired for the terrestrial compressor and coated with a Teflon layer.

Meanwhile it was noted that the divergent rotameter, fitted during all experiments played some role in oil separation. Some oil was observed to be returned to the exhaust although the majority was found to escape and had to be returned to the expander sump at the end of each experiment.

### 3. DATA PROCESSING AND RESULTS

#### 3.1 Expander characterisation issues

Calculation of expander work output and efficiency under various operating conditions is essential in determining the domain of suitability of a given expander.

The dynamo used to load the automotive compressors had a separate field current supply, which could be varied so as to alter the torque-speed characteristics ( $k\phi$ ) of the load. The shaft speed was measured directly with a magnetic coil tachometer and the torque was estimated from the electrical output.

For given  $k\phi$ , measurements were taken for various loads by connecting the stator coils to a variable rheostat. The current through the stator was determined and the voltage across the coils measured at each point.

Shaft power was estimated by finding the DC impedance of the stator coils and adding the associated  $I^2 R$  dissipation loss to the electrical power measured. Mechanical losses in the electrical machinery were assumed negligible. Torque was calculated directly from shaft power and speed.

The delta connected three phase induction motor of the terrestrial scroll was fitted with power factor correction capacitors, sized to counteract the inline stator and referred rotor inductances at 415V (50Hz). It was later found that these capacitances were oversized as the torques achieved were not high enough to export efficiently above 200V.

A variable transformer (variac) was connected between the induction machine and the 415V supply. Two of the

phases were swapped in order to reverse the direction of rotation. The machine was initially started with a controlled compressed air supply at zero load before the motor was switched in at 0V phase voltage. The load was increased to operating point by increasing the variac setting to the desired voltage. RMS currents and power factors were measured for each phase during operation.

The figure below depicts the equivalent circuit for one phase of a 3 phase induction motor running as a generator. The currents have been chosen to be positive in the motor convention so that negative slips and current values result. This was done to enable easy comparison with motor data supplied by the manufacturer.

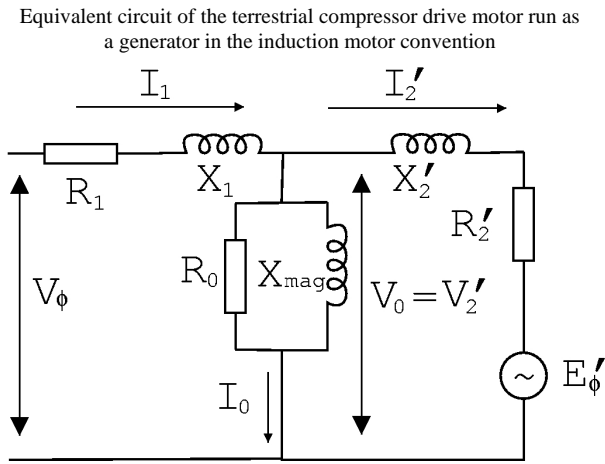

In order to obtain an estimate of shaft power, the DC, no-load and locked rotor parameters ( $R_1$ ,  $R_0$  &  $X_{mag}$  and  $R_2'$ ,  $X_1$  &  $X_2'$  respectively) were measured at a range of phase voltages.

The referred back EMF generated on each phase,  $E'_\phi$  and the referred rotor current  $I'_2$  were estimated from knowledge of  $V_\phi$ ,  $I_1$  and the equivalent circuit parameters. This enabled direct calculation of the shaft power, which is given by:

$$\dot{W}_s = 3I'_2 E'_\phi \quad \text{Eq. (13)}$$

From induction motor theory, the rotor slip is then calculated as:

$$s = \frac{I'_2 R'_2}{E'_\phi + I'_2 R'_2} \quad \text{Eq. (14)}$$

From the slip, shaft speed is obtained and torque is obtained from shaft speed and shaft power.

Measuring and calculating isentropic expander efficiencies is not trivial. Firstly, the intake and exhaust states of the gas stream must be found. Although the intake temperature may be measured fairly accurately, transients in the exhaust stream may take a significant

time to decay, as the scroll set has a high thermal capacity and performance may be intermittent.

Therefore, rather than measuring the exhaust temperature directly, a reasonably accurate figure may be estimated by an iterative extrapolation from the intake pressure and temperature,  $P_1$  and  $T_1$  together with the exhaust pressure and volumetric exhaust flowrate,  $P_2$  and  $U_2$  respectively. The fluctuation timescales of these quantities are less than the exhaust stream temperature and they are relatively easy to measure.

Graphical representation of the extrapolation technique used to obtain isentropic expansion efficiencies

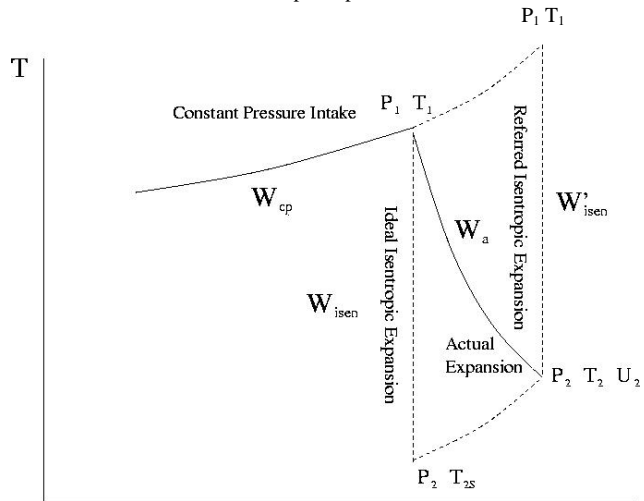

The T-S diagram above depicts the extrapolation used to calculate isentropic efficiencies. The extrapolation involves calculating the enthalpy change along the exhaust isentrope and scaling it back to intake conditions along the lines of constant pressure. The working fluid is dry air.

### 3.2 Results of the air line tests

Shaft power was inserted into the isentropic-mechanical efficiency extrapolation from equation (13) and used to obtain the following set of values to within 10%:

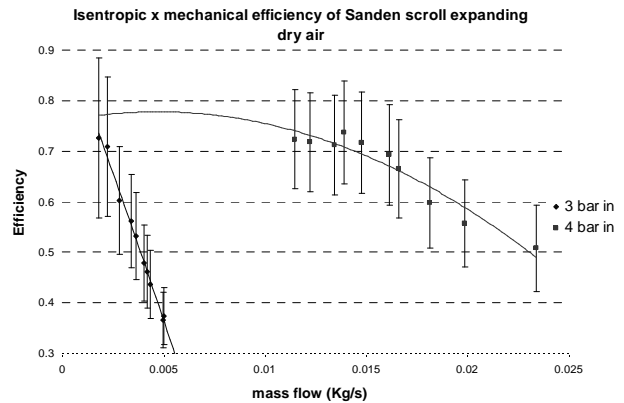

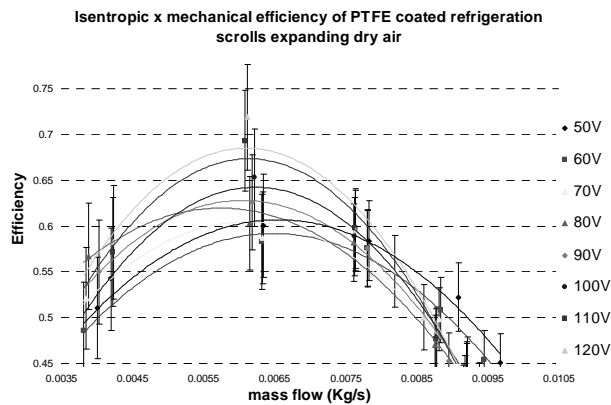
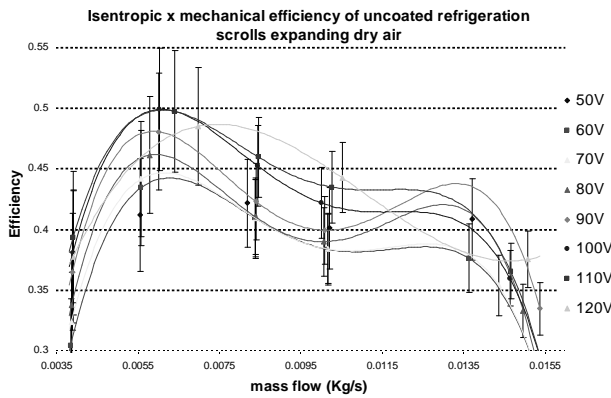

### 3.3 Modelling the assembled system

In order to estimate  $C_T$  and  $C_L$  values for various sizes of plant and to estimate stabilisation rates, a 'lumped element' control model was constructed. In the model, the efficiency parameters, heat capacity and internal volume of the best performing collectors are used in combination with correlated properties of methl-alcohol and n-pentane in a 'vapour generation subroutine'. A quantity of vapour is generated resulting in a small rise in pressure. The boiler and condenser pressures are passed to an expander subroutine which calculates shaft power and mass flow as follows:

- Shaft power is calculated through volumetric ratio and mean pressure correlations to experimental data.
- Peak isentropic x mechanical efficiency = 0.75 where conditions exactly match compressor volumetric ratio.
- If the volumetric ratio of the supply exceeds that of the expander, isentropic power is calculated between superheated vapour and *condenser intake* states only.
- If the volumetric ratio of the expander exceeds that of the supply, isentropic power is calculated between superheated vapour and *expander exhaust* states only.

The scaling of mechanical losses and 'blow by' with torque and shaft speed were not included.

The option of synchronous or asynchronous generating plant enables changes in dynamic behaviour due to fixed or variable shaft speed to be observed.

Torque-Speed curve of an asynchronous (induction) machine at different phase voltages.

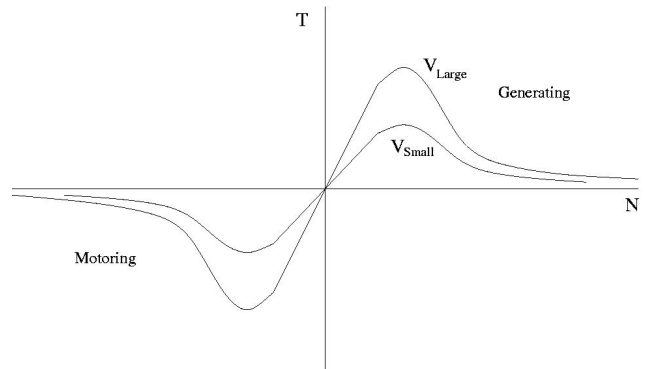

The generator subroutine is designed to take a shaft power value from the expander and pass back a speed, whilst calculating torque and electrical losses.

The condenser is modelled in the the same manner as the direct vapour generator (boiler), using heat capacity and internal volume to offset the model time-step in order to achieve a convergent solution.

Numerical model variation of net efficiency with infinite bus voltage

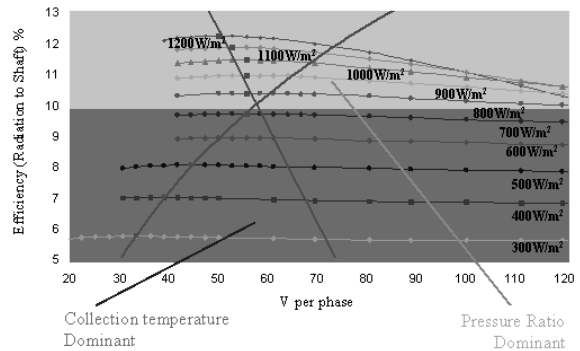

The model confirms that by exploiting the generator phase voltage and condenser coolant mass flows as free parameters, an approximately constant value for each causes the specific volume ratio of superheated vapour to condenser intake flow to remain constant. If incoming solar flux increases, provided a suitable phase voltage has been set, the boiling temperature and pressure will rise to a new optimum steady state with higher pressure and outlet mass flow. The simultaneous increase in heat load on the condenser results in a condensing pressure rise and implied fall in condenser inlet specific volume. The net result, as demonstrated in the figure above, is that the system operates close to its optimum regardless of incident solar flux.

## 4. CONCLUSIONS

The results obtained from the individual components and the modelled ensemble demonstrate that high quality,

low concentration solar hot water collectors can feasibly be integrated with pre-developed low cost technology to generate power for export to electrical grids.

By combining these results with production cost data supplied by the manufacturers of the preferred collector models, the following conclusions were made:

- Low concentration CPC with scroll expanders and asynchronous generators could export at €3.7 to €3.4/We (1KWe capacity) and €3.3 to €3.8/We (2KWe capacity) at  $G=1000\text{W/m}^2$ .
- These figures correspond to €0.028 to €0.039/KWh (Madrid) & €0.050 to €0.069/KWh (Cambridge) and €0.025 to €0.035/KWh (Madrid) & €0.045 to €0.063/KWh (Cambridge) for 1KWe and 2KWe rated plant over a 20 year period.
- Capacity ( $C_T$ ) Costs of approximately 2/3 this value may be possible using some of the *lowest* cost flat plate collectors. However, implied condensing heat loads and collector area requirements rule out this option except for niche applications.

The greatest technical obstacles to be surmounted are expander lubrication, waste heat removal and the selection and control of the feedpump:

- Inadequate provision of sealing lubricant and coupling pressure to the scrolls can cause polytropic efficiency loss in excess of 20%.
- This may be remedied by oil separation, boiler bypass and reinjection or by using elastomeric seals.
- Improving thermodynamic efficiency relies on high volumetric ratio and good wetness tolerance.
- The latter implies that the use of an immiscible lubricant and oil separator may be favourable to reliance upon controlled oil migration.
- Overall CC and LCC may be minimised by raising condensing temperatures and relying on free convection cooling of the condenser.
- Purely thermofluidic two phase pumps are being investigated as low cost, long lifetime, self starting feedpumps for ORC applications. These offer the additional advantages of being able to combine recuperation and feedpumping into a single space without moving parts.

If induction machines are to be run as asynchronous generators in domestic applications, the use of a dynamically controlled variable transformer would not be feasible. Two alternative options may be considered:

- Rewinding the stator of the generating machinery to optimize generating slip.
- Altering the synchronous voltage using a back to back inverter with dynamic feedback control.

The first of these options could be implemented without incurring an increase in production cost, yet a sacrifice in efficiency would be implied under off-peak insolation.

The second option would enable peak generating efficiency to be maintained under all conditions, yet a significant additional cost would be implied.

## REFERENCES

- Tamm G. and Goswami D. Y. (2003) Novel combined power and cooling thermodynamic cycle for low temperature heat sources. *J. Sol. En. Eng.*, 125(2), 223-229.
- Martin S., Kane M. and Favrat D. (2002) Small hybrid solar power system: First field test results. *Proceedings of the 1st International Conference on Heat Transfer, Fluid Mechanics, and Thermodynamics*, 8-10 April, Kruger Park, South Africa, Meyer J. P. (Ed), pp.442-448.
- Gnutek Z. and Bryszewska-Mazurek A. (2001). The thermodynamic analysis of multicycle ORC engine. *Energy*, 26(12), 1075-1089.
- Perry R.H. and Green D.W. (1997) *Perry's Chemical Engineer's Handbook*, 7<sup>th</sup> edn. McGraw Hill.
- Zábranský M., Ruzicka V., Majer V., et al. (1996). Heat capacity of liquids: Critical review and recommended values. *J. Phys. Chem. Ref. Dat.*, 1 and 2 (Monograph 6).
- Majer V. and Svoboda V. (1985) *Enthalpies of Vapourisation of Organic Compounds: A Critical Review and Data Compilation*. Blackwell.
- Kane M., Larrain D., Favrat D. et al. (2001) Small hybrid solar power system. *In Proceedings of ECOS'01*, 4-6 July, Istanbul, Turkey, p.4.